

Fit it & Forget it

Why people prefer an
A. O. Smith water heater...



EWS: Available in 6 to 25 litre capacities



ELJV & ELJH: Available in 35 to 100 litre capacities

QUALITY



American technology that ensures you have a water heater that works in Indian water conditions.

RELIABILITY



Heating technology that will always give you hot water... Guaranteed!

PREMIUM



Our new innovative solutions are often copied but never equalled.

ENERGY SAVING



Saves time.
Saves energy.
Saves money.

INNOVATIVE



Blue Diamond
Glass-Lined Tanks.
Glass Coated Elements.
Colour Options.

EXCELLENT SERVICE



Guaranteed Service
within 24 hours.
Call: 1800.103.2468

In 1936, A. O. Smith developed and patented a process to glass-line water heaters. Over the years, A. O. Smith has gained the respect and support of homeowners, contractors, architects, and specifying engineers in over 60 countries by providing innovative energy efficient products designed for years of trouble-free service.

Today, A. O. Smith Water Products Company, the largest water heater manufacturer in North America, a division of A. O. Smith Corporation, is a global leader in innovative technology and energy efficient solutions.

AO SmithTM
Innovation has a name.



KEY FEATURES



1 GLASS COATED ELEMENT

Scale and sediment on the surface of the element can lead to premature failure. A. O. Smith Glass Coated Element helps prevent scale formation and extends element life.



2 BLUE DIAMOND Glass Lining offers the best protection against tank corrosion

Patented Blue Diamond technology increases life of the water heater. The lining is stronger and more water-resistant than any other in the industry.

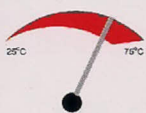

3 TEMPERATURE CONTROL KNOB

The Temperature Control Knob allows you to set the temperature precisely and between 25°C and 75°C.



4 SAFETY VALVE discharges water in case pressure or temperature exceeds preset limits

The safety valve [not seen in picture] automatically discharges water in case the pressure or temperature overshoots preset limits.

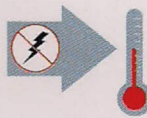

5 THERMAL CUTOUT cuts off electrical power to the unit if a fault occurs, ensuring safety

In case a fault occurs and the water temperature exceeds the highest preset temperature, the thermal cutout cuts off the power supply to guarantee safety.



6 4 YEARS EXTENDED WARRANTY*

The tank carries a 7 year warranty. The heating element has a 2 year warranty that can be extended to 4 years if registered within the first 2 months of purchase. All other parts carry a 2 year warranty.

*Above warranty applies only if the water heater is purchased from our authorised dealer.

EWS

6, 10, 15, 25 Litres



SPECIFICATIONS

MODEL	EWS-6	EWS-10	EWS-15	EWS-25
Capacity [ltrs.]	6	10	15	25
Wattage [kW]	2	2	2	2
Max Stdg. Loss [kWh/24h/45°C diff.]	0.792	0.99	1.138	1.386
Actual Stdg. Loss [kWh/24h/45°C diff.]	0.444	0.561	0.622	0.770
Reheating Time for 50°C rise [in min]	16	33	48	72
Rated Pressure [bar]	8	8	8	8

DIMENSIONS

MODEL	EWS-6	EWS-10	EWS-15	EWS-25
A [mm]	317	373	373	444
B1 [mm]	317	373	373	444
B2 [mm]	326	380	382	453
C [mm]	258	277	348	383

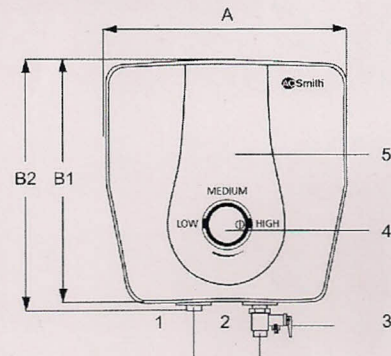

PART DESCRIPTORS

- | | |
|--------------------------|-------------------------|
| 1 Outlet | 8 Anode |
| 2 Inlet | 9 Heating Element |
| 3 Safety Valve | 10 Tank |
| 4 Thermostat Knob | 11 Installation Bracket |
| 5 Decorative Front Panel | 12 PU Insulation |
| 6 Front Jacket | 13 Thermal Cutout |
| 7 Back Jacket | |

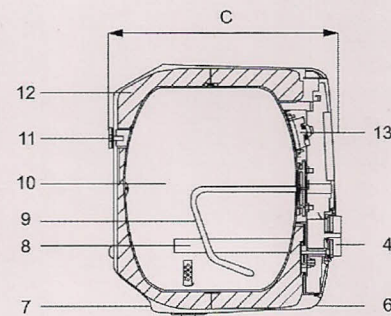

A. O. SMITH COLOURMATCH SYSTEM™

The A. O. Smith ColourMatch System™ allows your water heater to match the colours of your bathroom.

Call the A. O. Smith Customer Care Centre [1.800.103.2468] to order one of the Decorative Front Panel colour options, and we will have it delivered free of charge.



WHITE BLUE STEEL GREY LAVENDER IVORY RED BRICK OLIVE BROWN

* Printed colours shown above are only indicative and may vary from actual colours available.

ELJV/ELJH

35, 50, 70, 100 Litres



SPECIFICATIONS

MODEL	ELJV - VERTICAL WALL MOUNTED				ELJH - HORIZONTAL WALL MOUNTED			
	35	50	70	100	35	50	70	100
Capacity [ltrs.]	35	50	70	100	35	50	70	100
Wattage [kW]	2	2	3	3	2	2	3	3
Voltage Frequency [V/Hz]	220/50	220/50	220/50	220/50	220/50	220/50	220/50	220/50
Max Stdg. Loss [kWh/24h/45°C diff.]	1.584	1.832	2.079	2.376	1.584	1.832	2.079	2.376
Actual Stdg. Loss [kWh/24h/45°C diff.]	0.793	0.917	1.041	1.189	0.793	0.917	1.041	1.189
Rated Pressure [bar]	8	8	8	8	8	8	8	8

DIMENSIONS

MODEL	ELJV - VERTICAL WALL MOUNTED				ELJH - HORIZONTAL WALL MOUNTED			
	35	50	70	100	35	50	70	100
A mm [Diameter]	360	360	463	463	395	395	463	463
B mm [Length]	710	760	800	995	710	830	860	1025

PART DESCRIPTORS

- 1 Thermometer
- 2 Heating element
- 3 Anode
- 4 Cold water inlet pipe with diffuser
- 5 Hot water outlet pipe
- 6 Control thermostat and thermal cutout reset button
- 7 Multi-function safety valve
- 8 Stop cock
- 9 Pilot light
- 10 Blue ring
- 11 Red ring

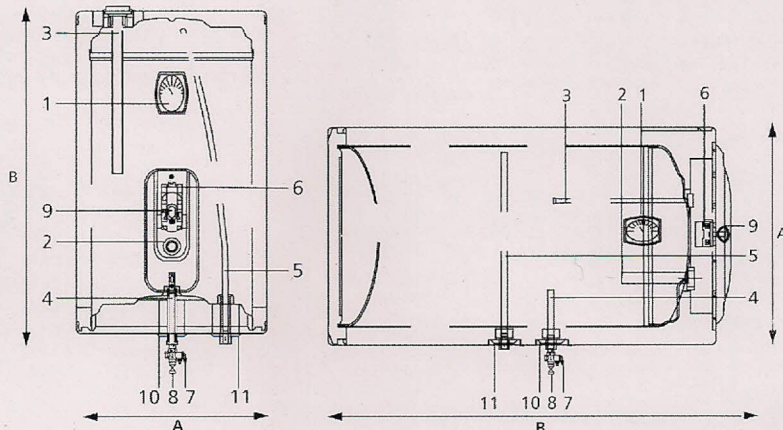

Contact your friendly A. O. Smith dealer today:

AC SmithTM
Innovation has a name.

Manufactured by A. O. Smith India Water Heating Private Limited

Plot No. 300, Phase - 2, KIADB Industrial Area, Harohalli, Taluka Kanakpura, Dist. Ramanagaram - 562 112, Karnataka, India
Toll Free: 1.800.103.2468 ■ Website: www.aosmithindia.com